

# Genie A

Generates ultrapure water and RO water on demand from the system

Genie A is a plug-and-play lab water system with small foot print. It is an ideal choice for users who need up to 20 liters of ultrapure water or RO water per day. Quality of ultrapure product water meets or exceeds ASTM, CLSI, CAP, and ISO Type I water standards.

The system is manufactured in an ISO 9001 : 2015 certified manufacturing site.

## Features

- Wireless communication amongst components providing unlimited possibilities
- RFID tracking of consumables and RO membranes to ensure optimal system performance
- No storage tank needed: eliminating potential contamination from the storage tank
- Compact design: no additional pre-treatment filters required; remote dispenser on the system
- Consistent and stable RO permeability over a wide range of temperature
- A full range of cartridges for various applications including ultra-low TOC, low Mg, low boron, ICP and DI type
- Choices of final filters to remove specific contaminants
- Automatic system shut-off upon detection of any water leakage

## Main Components



### Command and control center

- 8-inch touch screen allowing easy control and operation of the system
- Comfortable viewing and operation with built in viewing angle and flexible placement by users
- Operable with gloves and wet hands
- Robust screen: easy to clean, resistant to scratches

## Control Console



Dispenser

### All-in-one touch screen

- Manual and volumetric dispensing, adjustable dispensing rate, and water quality monitoring
- Compact dispenser allowing one handed operation and control
- Operable with gloves and wet hands
- Height adjustable and 360 degree rotatable on an anti-skid base

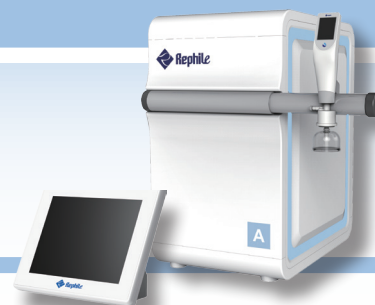

- Advanced wireless communication technologies offer more freedom than ever for a remote dispenser. Its distance from the system is no longer limited by the length of cables and wires.
- "1+N mode" - one water system can drive N units of dispenser (Up to 10 now and can be upgraded further more).
- Genie equips with multiple touch screens which are highly responsive, water-proof, latex glove friendly, and perfect for wet labs.
- Monitoring of consumables and accessories, through RFID technology, provides users with real-time operational intelligence.
- The ability to export and print data and log-in requirements are built into all of our Genie systems.
- Feed water conductivity monitoring ensures optimal running conditions of the system.
- A RephiBio filter can be embraced to produce pyrogen, nuclease and bacteria free water for critical applications.
- No tools are needed for system maintenance and simple service.

**NEW**

**A**



Cartridges

### Cartridges

- Improved stability of water quality & efficiency of polishing resins due to optimized flow design
- High pressure rated housings, proprietary sealing, and double o-ring designs ensuring operational confidence
- A worry-free installation with three verifications: color, words, and RFID recognition

## Specifications

Genie A	
Feed Water Requirements	
Feed water conductivity / TDS	< 2000 $\mu\text{S/cm}$ / < 1000 ppm
Operating temperature	5 - 45 $^{\circ}\text{C}$
Feed water pressure	1 - 6 $\text{kg/cm}^2$ (15 - 90 psi)
Product Water Quality	
RO water	
Dispenser rate	Typically 0.5 L/min
Conductivity ( @ 25 $^{\circ}\text{C}$ )	Typically < 20 $\mu\text{S/cm}$ (feed water < 2000 $\mu\text{S/cm}$ )
Ultrapure water	
Dispenser rate	Typically 0.5 L/min
Resistivity ( @ 25 $^{\circ}\text{C}$ )	18.2 $\text{M}\Omega\cdot\text{cm}$
TOC*	< 5 ppb
Particles ( > 0.2 $\mu\text{m}$ )**	No Particles with size > 0.22 $\mu\text{m}$
Microorganisms***	< 0.1 cfu/ml
Pyrogens (endotoxins)****	< 0.001 Eu/ml
RNAse****	< 0.5 pg/ml
DNAse****	< 10 pg/ml
Dimensions	
Main system: Width x Depth x Height	32 cm x 44 cm x 54 cm

\* Product water quality may vary due to local feed water conditions.

\*\* with a 0.2  $\mu\text{m}$  final filter

\*\*\* with a 0.2  $\mu\text{m}$  final filter or RephiBio filter

\*\*\*\* with a RephiBio filter

## Ordering Info

Description	Cat. No.
Genie A System	RG0A04000
Genie A System, with TOC	RG0A040T0

## Main Applications

### With Ultrapure Water

- HPLC mobile phase preparation
- Preparation of reagent blank solutions
- As sample diluent for GC, HPLC, ICP-MS, AA and other analytical techniques
- Preparation of buffers and culture media for mammalian cell culture
- Preparation of molecular biology reagents, etc.

### With RO Water

- Glassware cleaning
- Washing machine for glassware
- Water bath water
- Autoclave
- Feed water for laboratory animals

## Flow Chart

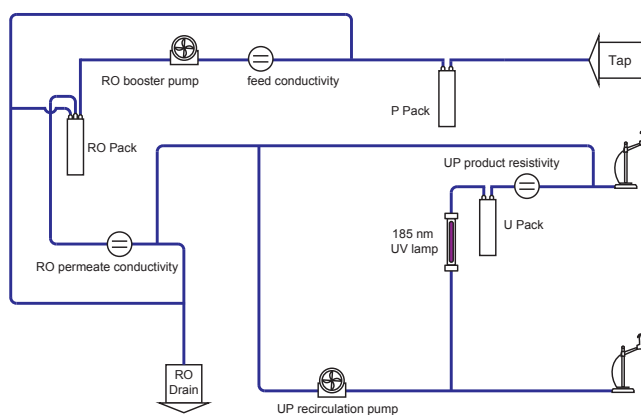

All rights reserved © 2018 RephiLe Bioscience, Ltd.  
RephiLe, Genie and PURIST are registered trademarks of RephiLe Bioscience, Ltd.. TM and (R) may be omitted in this brochure.

### RephiLe Bioscience, Ltd.

Toll Free: +1-855-RephiLe (+1-855-737-4453)

E-mail: [info@rephile.com](mailto:info@rephile.com)



Literature: RFP1401809